

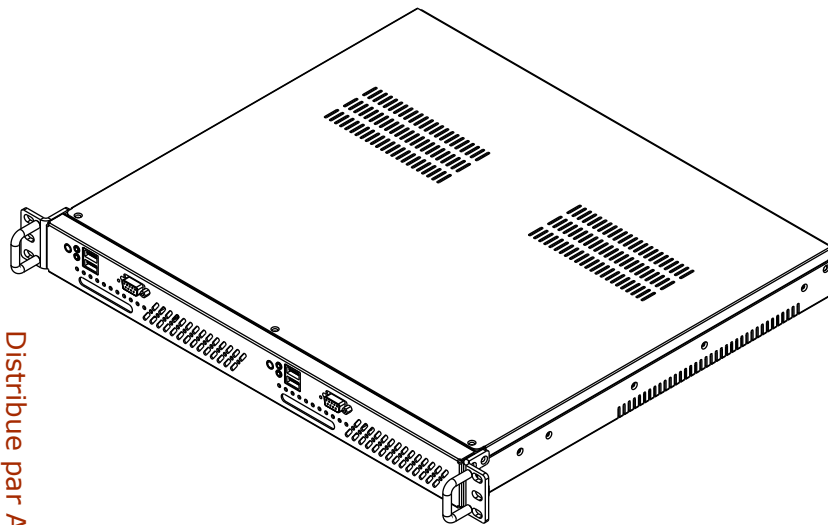

**Travla C147**  
**1U 15 INCH DUAL-MOTHERBOARD**  
**mini-ITX RACKMOUNT CHASSIS**  
**QUICK START**  
**USER GUIDE**



Distribue par Anteor - www.anteor.com Tel : 01 61 37 07 00

**1. Remove top cover**

Remove screw "A" (x3)

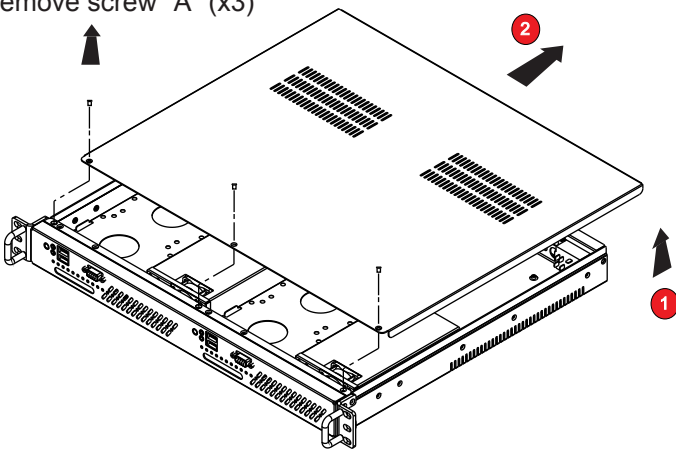

1. Lift cover upward

2. Slide top cover to rear

**Screw Identification Guide**

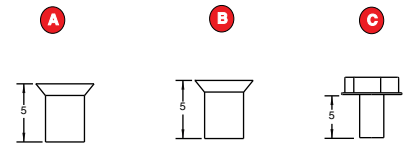

- A. Flat head screw #6-5mm
- B. Flat head screw M3-5mm
- C. Hex head screw #6-5mm

**Index**

- 1) Remove Top Cover
- 2) Install 3.5" HDD to drive bay holder
- 3) Install compact flash to drive bay holder
- 4) Install 2.5" HDDs to drive bay holder
- 5) Install drive bay holder with 2.5" HDDs to 1U chassis
- 6) Install drive bay holder with 3.5" HDDs to 1U chassis
- 7) Install motherboards to 1U chassis

**Front Connectors**

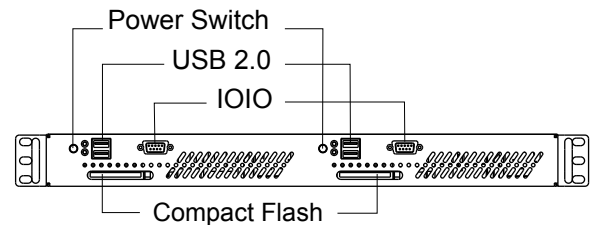

**Rear Connectors**

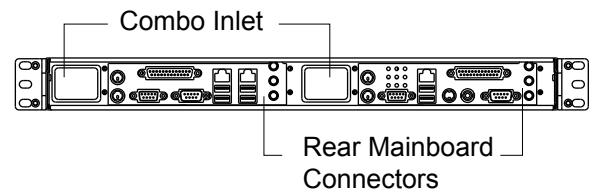

**WARNING:** Install and service to this product is performed only by qualified personnel to avoid risk of injuries.

## 2. Install 3.5" HDD to drive bay holder

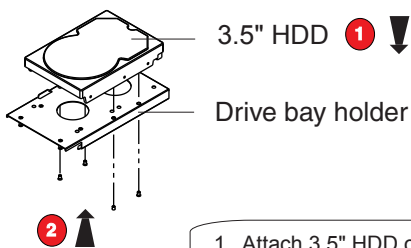

1. Attach 3.5" HDD on top of the drive bay holder

2. Install screw "A" (x4)

## 3. Install compact flash to drive bay holder

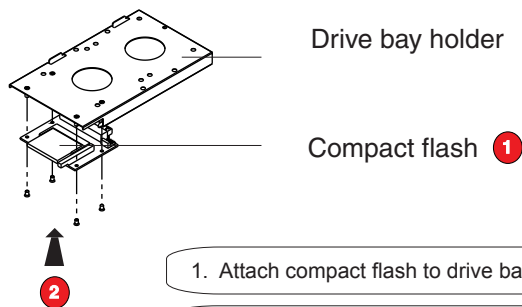

1. Attach compact flash to drive bay holder

2. Install screw "B" (x4)

## 4. Install 2.5" HDDs to drive bay holder

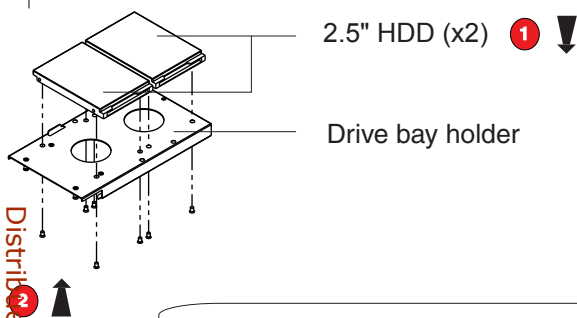

1. Attach 2.5" HDDs on top of the drive bay holder

2. Install screw "B" (x8)

## 5. Install drive bay holder with 2.5" HDDs to 1U chassis

Note: view without front panel

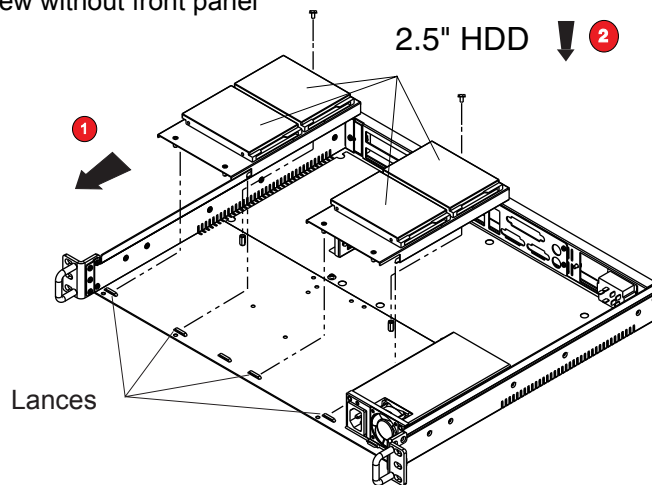

1. Slide each drive bay holder into lances as shown above

2. Install screw "C" (x2)

## 6. Install drive bay holder with 3.5" HDDs to 1U chassis

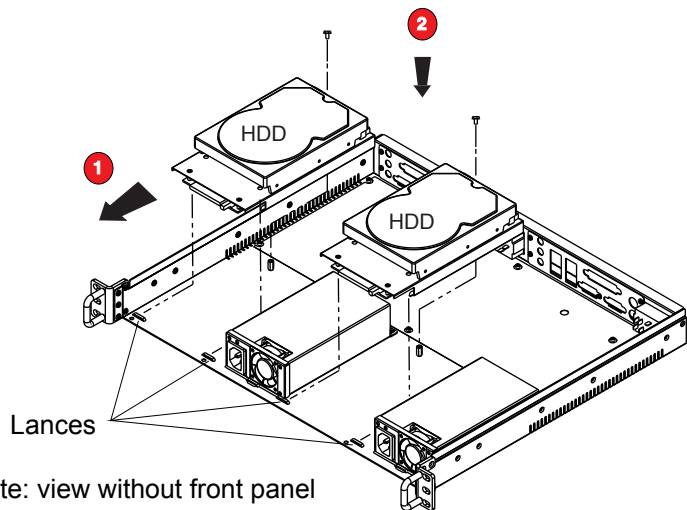

Note: view without front panel

1. Slide each drive bay holder into lances as shown above

2. Install screw "C" (x2)

## 7. Install motherboards to 1U chassis

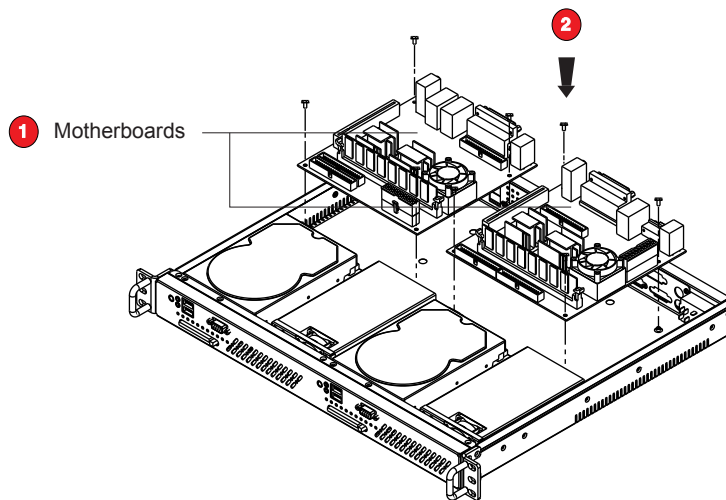

1. Place motherboards onto 1U chassis with the right I/O gasket

2. Install screw "C" (x8)